



The new degree of comfort.®

Endeavor™ Line *Classic Plus*® Series iM Air Conditioners



This product meets a stringent set of our internally defined sustainability standards



RA16AZ

EcoNet® Enabled

Cooling Efficiencies up to: 17 SEER2/10.5 EER2

Nominal Sizes: 2 to 5 Tons [7.0 to 17.6 kW]

Cooling Capacities: 23.5 kBTU to 56 kBTU [6.9 to 16.4 kW]



The Bluetooth® word mark and logos are registered trademarks owned by Bluetooth SIG, Inc. and any use of such marks by Rheem® is under license. Other trademarks and trade names are those of their respective owners.

Table of Contents

Features & Benefits	3
Model Number Identification	4
General Data/Electrical Data	5
Accessories	6
Unit Dimensions	7
Clearances	8
Control Wiring	9
Application Guidelines.....	9
Refrigerant Line Size Information	10-11
Performance Data	12
Smart Home Systems	13
Limited Warranty	16

Features and Benefits

- **EcoNet® Enabled:** Automatic system configuration and optimization
- **PlusOne® Diagnostics & Bluetooth®¹ Connectivity:** With the Rheem Contractor & EcoNet® Apps, built-in technology makes advanced set-up, monitoring, troubleshooting and repairing the product easier than ever before
- **PlusOne® Variable Speed Twin Rotary Compressor & Inverter Drive:** Features Inverter operation from 40 to 100% capacity with the EcoNet® Smart Thermostat
- **3-Speed Operation:** When installed with a 24V two-stage thermostat
- **Provides Precise Temperature Control:** Advanced humidity control and greater efficiency
- **Brushless DC Condenser Motors (BLDC):** Enhances reliability and allows for easier serviceability
- **Swept Wing Fan Technology:** Features quieter operation and improved unit acoustics
- **7mm Condenser Copper Coil:** Requires less refrigerant allowing for a smaller and lighter footprint while enhancing reliability
- **PlusOne® Expanded Valve Space:** 3 in. – 4in. – 5 in. service valve space—provides a minimum working area of 27-square inches for easier access
- **PlusOne® Triple Service Access:** 15 in. wide, industry leading corner service access, two fastener, removeable corner and individual louver panels—makes repairs easier and faster

¹The Bluetooth® word mark and logos are registered trademarks owned by Bluetooth SIG, Inc. and any use of such marks by Rheem® is under license. Other trademarks and trade names are those of their respective owners.

Air Conditioners

<u>R</u>	<u>A</u>	<u>16</u>	<u>A</u>	<u>Z</u>	<u>24</u>	<u>A</u>	<u>J</u>	<u>3</u>	<u>C</u>	<u>A</u>	<u>LHP</u>
Brand	Product Category	SEER2	Region	Refrigerant	Capacity BTU/HR	Major Series	Voltage	Type	Controls	Minor Series	Option Code
R - Rheem	A - Air Conditioners	16 - 16 SEER2	A - All	Z - R-410A	24 - 24,000 [7.03 kW] 36 - 36,000 [10.55 kW] 48 - 48,000 [14.07 kW] 60 - 60,000 [17.58 kW]	A - 1st Design	J - 1ph, 208-230/60	3 - 3+ Stage	C - Communicating	A - 1st Design	LHP - W/HLPC

[] Designates Metric Conversions

AVAILABLE MODELS	DESCRIPTION
RA16AZ24AJ3CA	Endeavor™ Line <i>Classic Plus</i> ® Series 2 ton EcoNet® Enabled 3+ Speed iM Air Conditioner – 208/230/1/60
RA16AZ36AJ3CA	Endeavor™ Line <i>Classic Plus</i> ® Series 3 ton EcoNet® Enabled 3+ Speed iM Air Conditioner – 208/230/1/60
RA16AZ48AJ3CA	Endeavor™ Line <i>Classic Plus</i> ® Series 4 ton EcoNet® Enabled 3+ Speed iM Air Conditioner – 208/230/1/60
RA16AZ60AJ3CA	Endeavor™ Line <i>Classic Plus</i> ® Series 5 ton EcoNet® Enabled 3+ Speed iM Air Conditioner – 208/230/1/60

STANDARD EQUIPMENT
R-410A Refrigerant
Scroll Compressor
Field Installed Filter Drier
Front Seating Service Valves
Internal Pressure Relief Valve
Internal Thermal Overload
Long Line capability
Low Ambient capability with Kit
3-4-5 Expanded Valve Space
Composite Basepan
2 Screw Control Box Access
15" Access to Internal Components
Quick release louver panel design
No fasteners to remove along bottom
Optimized Venturi Airflow
Single row condenser coil
Powder coated paint
Rust resistant screws
QR code
External gauge ports
Service trays

*5T Model SEER2: 15.5 SEER2

General Data				
MODEL NO.	RA16AZ24AJ3	RA16AZ36AJ3	RA16AZ48AJ3	RA16AZ60AJ3
Nominal Tonnage	2.0	3.0	4.0	5.0
Valve Connections				
Liquid Line O.D. – in.	3/8	3/8	3/8	3/8
Suction Line O.D. – in.	3/4	3/4	7/8	7/8
Refrigerant (R410A) furnished oz.¹	91	119	130	154
Compressor Type	Twin Rotary			
Outdoor Coil				
Net face area – Outer Coil	11.79	14.4	16.42	17.88
Net face area – Inner Coil	—	—	—	—
Tube diameter – in.	0.276	0.276	0.276	0.276
Number of rows	1	1	1	1
Fins per inch	24	24	24	24
Outdoor Fan				
Diameter – in.	20	24	24	26
Number of blades	3	3	3	3
Motor hp	1/5	1/5	1/3	1/2
CFM	2883	4138	4508	5348
RPM	1075	1000	1075	1075
watts	168	267	297	379
Shipping weight – lbs.	153	157	195	211
Operating weight – lbs.	146	150	188	204
Electrical Data				
Line Voltage Data (Volts-Phase-Hz)	208/230-1-60	208/230-1-60	208/230-1-60	208/230-1-60
Maximum overcurrent protection (amps)²	20	30	40	50
Minimum circuit ampacity³	12	20	25	32
Compressor				
Rated load amps	10	15	20	25
Locked rotor amps	65	70	96	119

¹Refrigerant charge sufficient for 15 ft. length of refrigerant lines. For longer line set requirements see the installation instructions for information about set length and additional refrigerant charge required.

²HACR type circuit breaker or fuse.

³Refer to National Electrical Code manual to determine wire, fuse and disconnect size requirements.

Accessories

MODEL NO.		RA16AZ24AJ3	RA16AZ36AJ3	RA16AZ48AJ3	RA16AZ60AJ3
Compressor crankcase heater*		X	X	X	X
Low ambient control		Factory Installed	Factory Installed	Factory Installed	Factory Installed
Compressor sound cover		Factory Installed	Factory Installed	Factory Installed	Factory Installed
Compressor hard start kit		Factory Installed	Factory Installed	Factory Installed	Factory Installed
Compressor time delay		Factory Installed	Factory Installed	Factory Installed	Factory Installed
Low pressure control		X	X	X	X
High pressure control		Factory Installed	Factory Installed	Factory Installed	Factory Installed
Liquid Line Solenoid (24 VAC, 50/60 Hz)	Solenoid Valve	200RD2T3TVLC	200RD2T3TVLC	200RD2T3TVLC	200RD2T3TVLC
	Solenoid Coil	61-AMG24V	61-AMG24V	61-AMG24V	61-AMG24V
Liquid Line Solenoid (120/240 VAC, 50/60 Hz)	Solenoid Valve	200RD2T3TVLC	200RD2T3TVLC	200RD2T3TVLC	200RD2T3TVLC
	Solenoid Coil	61-AMG120/240V	61-AMG120/240V	61-AMG120/240V	61-AMG120/240V

*Crankcase Heater recommended with Low Ambient Kit.

Weighted Sound Power Level (dBA)

UNIT SIZE - VOLTAGE, SERIES	STANDARD RATING (DBA)	TYPICAL OCTAVE BAND SPECTRUM (DBA WITHOUT TONE ADJUSTMENT)							SOUND POWER LEVEL (DB(A)) WITH SOUND BLANKET
		125	250	500	1000	2000	4000	8000	
RA16AZ24AJ3	63.3	35.9	47.9	55.3	53.2	50.4	47.1	43.8	Sound Blankets - Standard
	71.7	46.1	59.1	63.2	60.8	58.7	56.5	47.9	
RA16AZ36AJ3	61.4	38.5	48.0	53.8	49.2	45.9	47.0	47.4	
	72.9	47.5	59.5	64.9	60.7	62.6	57.0	49.6	
RA16AZ48AJ3	63.8	42.3	45.9	53.5	48.9	45.8	59.1	36.4	
	76.2	49.4	61.4	68.1	53.9	60.8	57.4	48.5	
RA16AZ60AJ3	65.7	39.7	49.0	58.2	54.5	52.2	53.8	41.3	
	76.7	49.3	64.6	68.1	65.1	62.6	58.6	53.0	

NOTE: Tested in accordance with AHRI Standard 270-08 (not listed in AHRI)

Unit Dimensions

MODEL NO.	OPERATING						SHIPPING					
	H (Height)		L (Length)		W (Width)		H (Height)		L (Length)		W (Width)	
	INCHES	mm	INCHES	mm	INCHES	mm	INCHES	mm	INCHES	mm	INCHES	mm
RA16AZ24AJ3	27.00	686	29.75	756	29.75	756	28.50	724	32.38	822	32.38	822
RA16AZ36AJ3	27.00	686	33.75	857	33.75	857	28.50	724	36.38	924	36.38	924
RA16AZ48AJ3	31.00	787	33.75	857	33.75	857	32.50	826	36.38	924	36.38	924
RA16AZ60AJ3	31.00	787	35.75	908	35.75	908	32.50	826	38.38	975	38.38	975

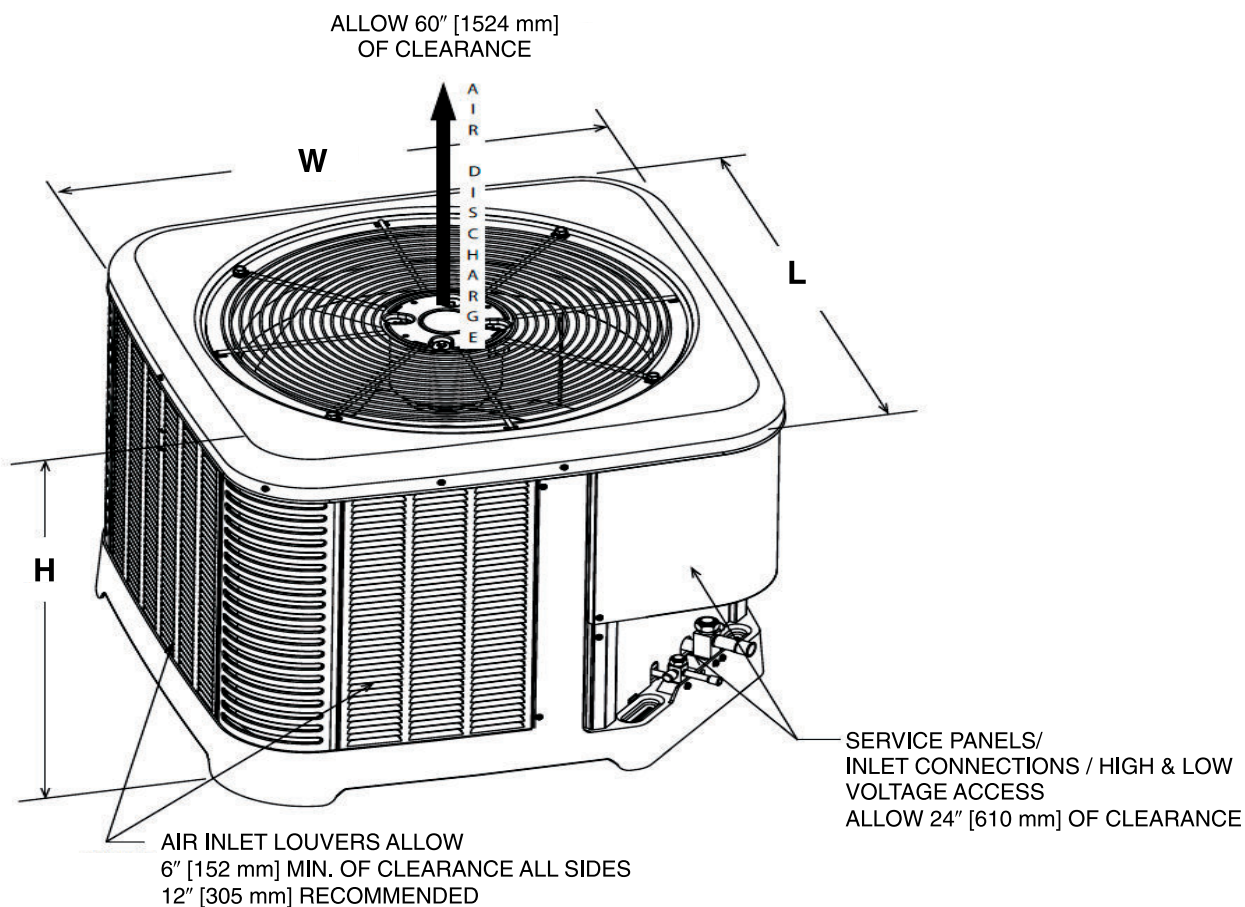

[] Designates Metric Conversions

ST-A1226-02-00

CLEARANCES

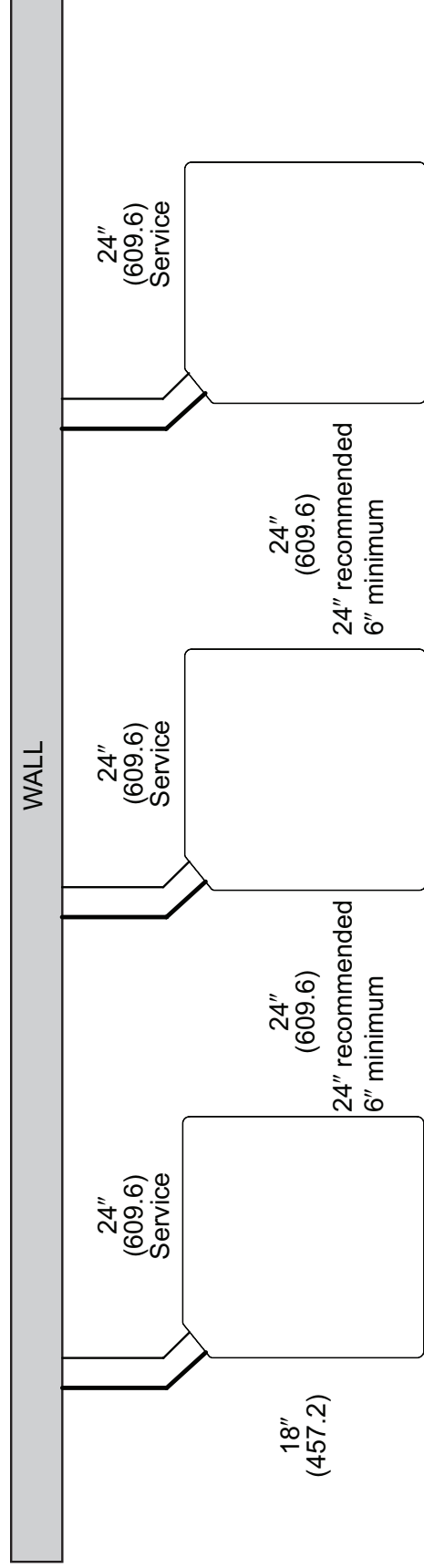
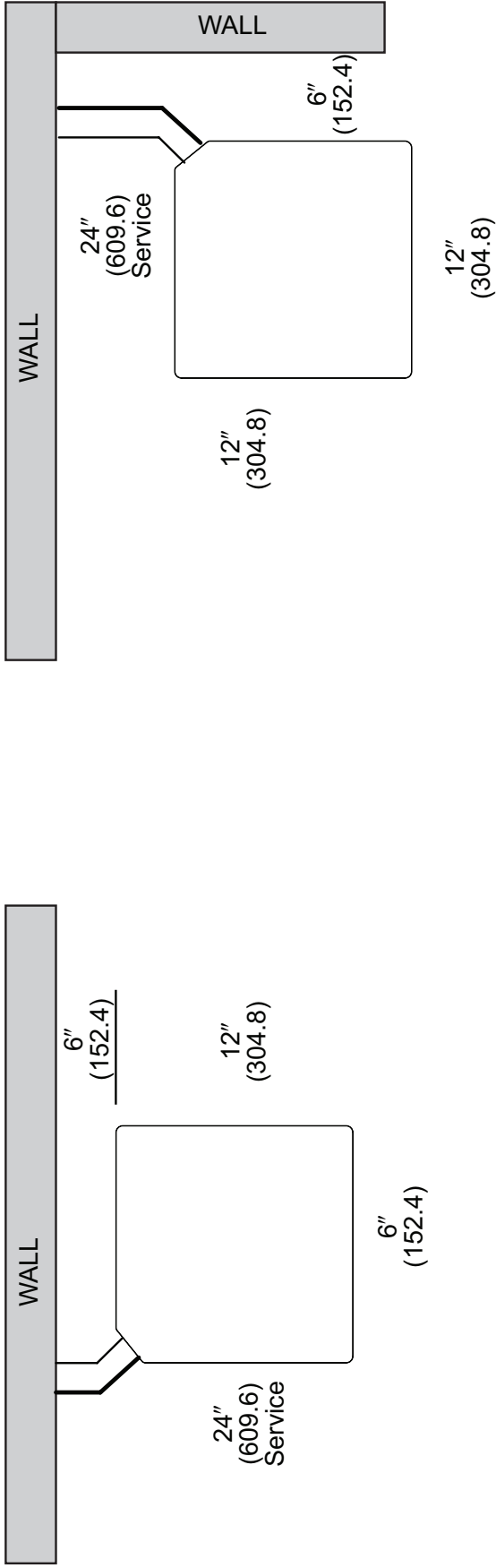

NOTE: NUMBERS IN () = mm

IMPORTANT: When installing multiple units in an alcove, roof well or partially enclosed area, ensure there is adequate ventilation to prevent re-circulation of discharge air.

Control Wiring

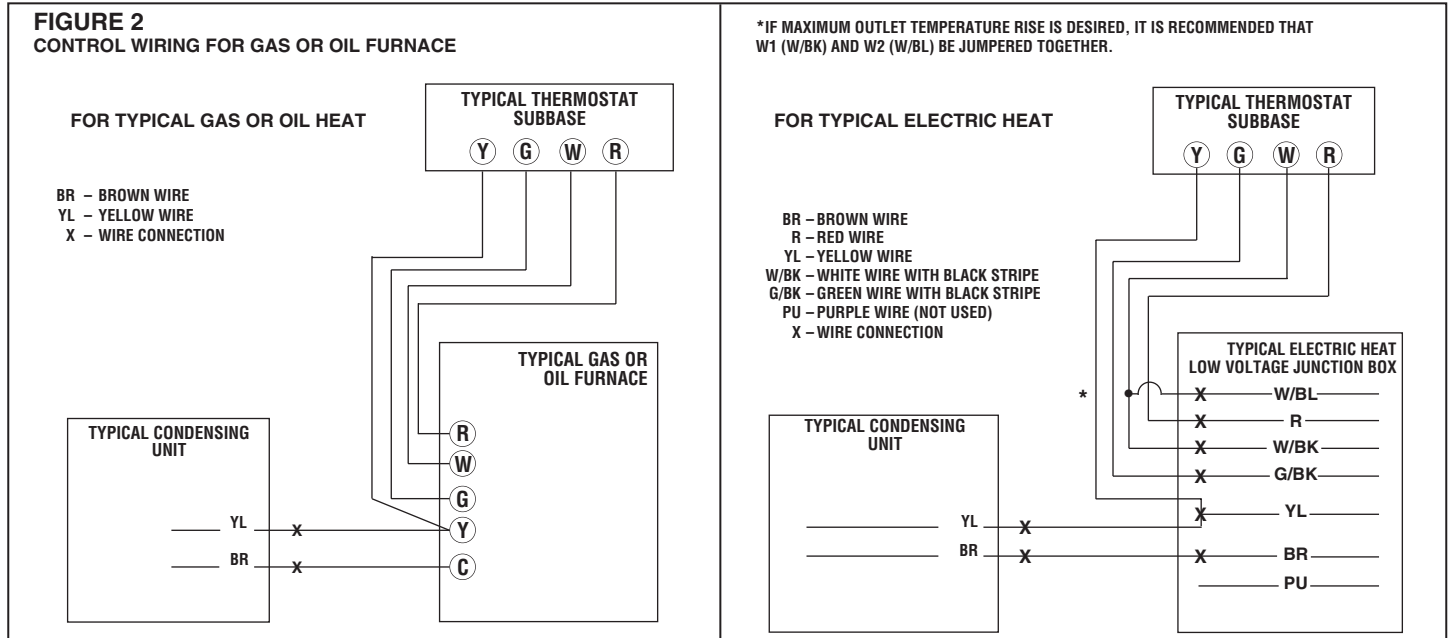

Application Guidelines

1. Intended for outdoor installation with free air inlet and outlet. Outdoor fan external static pressure available is less than 0.01 -in. wc.
2. Minimum outdoor operation air temperature for cooling mode without low-ambient operation accessory is 55°F (12.8°C).
3. Maximum outdoor operating air temperature is 125°F (51.7°C).
4. For reliable operation, unit should be level in all horizontal planes.
5. Use only copper wire for electric connections at unit. Aluminum and clad aluminum are not acceptable for the type of connector provided.
6. Do not apply capillary tube indoor coils to these units.
7. Factory-supplied filter drier must be installed.

Refrigerant Line Size Information

15/16 SEER2 VARIABLE SPEED AIR CONDITIONERS								
UNIT SIZE	ALLOWABLE LIQUID LINE SIZE	ALLOWABLE VAPOR LINE SIZE	OUTDOOR UNIT ABOVE OR BELOW INDOOR UNIT EQUIVALENT LENGTH (FEET)					
			< 25	26-50	51-75	76-100	101-125	126-150
			MAXIMUM VERTICAL SEPARATION / CAPACITY MULTIPLIER					
2.0 Ton **SEE NOTE 3	1/4"	5/8"	25/1.00	50/0.99	32/0.98	40/0.97	NR	NR
	5/16"	5/8"	25/1.00	50/0.99	50/0.98	50/0.97	50/0.96	50/0.95
	3/8"	5/8"	25/1.00	50/0.99	50/0.98	50/0.97	50/0.96	50/0.95
	1/4"	3/4"	25/1.00	50/1.00	32/0.99	40/0.99	NR	NR
	5/16"	3/4"	25/1.00	50/1.00	50/0.99	50/0.99	50/0.99	50/0.98
	3/8"	3/4"	25/1.00	50/1.00	50/0.99	50/0.99	50/0.99	50/0.98
3 Ton	5/16"	5/8"	25/0.99	50/0.97	50/0.95	50/0.93	37/0.91	NR
	3/8"	5/8"	25/0.99	50/0.97	50/0.95	50/0.93	50/0.91	NR
	5/16"	3/4"	25/1.00	50/0.99	50/0.99	50/0.98	37/0.97	22/0.96
	3/8"	3/4"	25/1.00	50/0.99	50/0.99	50/0.98	50/0.97	50/0.96
	1/2"	3/4"	25/1.00	50/0.99	50/0.99	50/0.98	50/0.97	50/0.96
4 Ton	3/8"	3/4"	25/0.99	50/0.98	50/0.97	50/0.96	50/0.94	50/0.93
	1/2"	3/4"	25/0.99	50/0.98	50/0.97	50/0.96	50/0.94	50/0.93
	3/8"	7/8"	25/1.00	50/0.99	50/0.99	50/0.98	50/0.98	50/0.97
	1/2"	7/8"	25/1.00	50/0.99	50/0.99	50/0.98	50/0.98	50/0.97
5 Ton	3/8"	3/4"	25/0.99	50/0.97	50/0.95	50/0.93	50/0.91	NR
	1/2"	3/4"	25/0.99	50/0.97	50/0.95	50/0.93	50/0.91	NR
	3/8"	7/8"	25/1.00	50/0.99	50/0.98	50/0.98	50/0.97	38/0.96
	1/2"	7/8"	25/1.00	50/0.99	50/0.98	50/0.98	50/0.97	50/0.96

NOTES:

- 1) Do not exceed 150 ft. linear line length.
- 2) *Do not exceed 50 ft. vertical separation if outdoor unit is above indoor unit.
- 3) **3/4" suction line should only be used for 2 ton systems if outdoor unit is below or at same level as indoor to assure proper oil return.
- 4) Always use the smallest liquid line allowable to minimize refrigerant charge.
- 5) Applications shaded in light gray indicate capacity multipliers between 0.90 and 0.96 which are not recommended, but are allowed.
- 6) Applications shaded in dark gray are not recommended due to excessive liquid or suction pressure drop.

Refrigerant Line Size Information (Con't.)

15/16 SEER2 VARIABLE SPEED AIR CONDITIONERS								
UNIT SIZE	ALLOWABLE LIQUID LINE SIZE	ALLOWABLE VAPOR LINE SIZE	OUTDOOR UNIT ABOVE OR BELOW INDOOR UNIT EQUIVALENT LENGTH (METERS)					
			< 25	26-50	51-75	76-100	101-125	126-150
			MAXIMUM VERTICAL SEPARATION / CAPACITY MULTIPLIER					
2.0 Ton **SEE NOTE 3	6.35 [1/4]	15.88 [5/8]	8/1.00	15/0.99	10/0.98	10/0.97	NR	NR
	7.94 [5/16]	15.88 [5/8]	8/1.00	15/0.99	15/0.98	15/0.97	15/0.96	15/0.95
	9.53 [3/8]	15.88 [5/8]	8/1.00	15/0.99	15/0.98	15/0.97	15/0.96	15/0.95
	6.35 [1/4]	19.05 [3/4]**	8/1.00	15/0.99	10/0.99	12/0.99	NR	NR
	7.94 [5/16]	19.05 [3/4]**	8/1.00	15/0.99	15/0.99	15/0.99	15/0.99	15/0.98
	9.53 [3/8]	19.05 [3/4]**	8/1.00	15/0.99	15/0.99	15/0.99	15/0.99	15/0.98
3 Ton	7.94 [5/16]	15.88 [5/8]	8/0.99	15/0.97	15/0.95	15/0.93	11/0.91	NR
	9.53 [3/8]	15.88 [5/8]	8/0.99	15/0.97	15/0.95	15/0.93	15/0.91	NR
	7.94 [5/16]	19.05 [3/4]	8/1.00	15/0.99	15/0.99	15/0.98	11/0.97	7/0.96
	9.53 [3/8]	19.05 [3/4]	8/1.00	15/0.99	15/0.99	15/0.98	15/0.97	15/0.96
	12.7 [1/2]	19.05 [3/4]	8/1.00	15/0.99	15/0.99	15/0.98	15/0.97	15/0.96
4 Ton	9.53 [3/8]	19.05 [3/4]	8/0.99	15/0.98	15/0.97	15/0.96	15/0.94	15/0.93
	12.7 [1/2]	19.05 [3/4]	8/0.99	15/0.98	15/0.97	15/0.96	15/0.94	15/0.93
	9.53 [3/8]	22.23 [7/8]	8/1.00	15/0.99	15/0.99	15/0.98	15/0.98	15/0.97
	12.7 [1/2]	22.23 [7/8]	8/1.00	15/0.99	15/0.99	15/0.98	15/0.98	15/0.97
5 Ton	9.53 [3/8]	19.05 [3/4]	8/0.99	15/0.97	15/0.95	15/0.93	15/0.91	NR
	12.7 [1/2]	19.05 [3/4]	8/0.99	15/0.97	15/0.95	15/0.93	15/0.91	NR
	9.53 [3/8]	22.23 [7/8]	8/1.00	15/0.99	15/0.98	15/0.98	15/0.97	12/0.96
	12.7 [1/2]	22.23 [7/8]	8/1.00	15/0.99	15/0.98	15/0.98	15/0.97	15/0.97

NOTES:

- 1) Do not exceed 46 meters linear line length.
- 2) *Do not exceed 15 meters vertical separation between indoor and outdoor units.
- 3) **19.05mm [3/4"] vapor line should only be used for 2 ton systems if outdoor unit is below or at same level as indoor unit to assure proper oil return.
- 4) Always use the smallest liquid line allowable to minimize refrigerant charge.
- 5) Applications shaded in light gray indicate capacity multipliers between 0.90 and 0.96 which are not recommended, but are allowed.
- 6) Applications shaded in dark gray are not recommended due to excessive liquid or suction pressure drop.

ADDITIONAL OIL, OZ.											
LINESET LENGTH	50	60	70	80	90	100	110	120	130	140	150
2T	N/A	N/A	N/A	N/A	N/A	1	2	3	5	6	7
3T	N/A	N/A	N/A	N/A	N/A	N/A	1	2	3	5	6
4T	N/A	N/A	N/A	N/A	N/A	N/A	N/A	N/A	N/A	N/A	N/A
5T	N/A	N/A	N/A	N/A	N/A	N/A	N/A	N/A	N/A	N/A	N/A

Performance Data @ AHRI Standard Conditions – Cooling

DESIGNATED TESTED COMBINATION (DTC)							
OUTDOOR UNIT	INDOOR COIL	TOTAL CAPACITY BTU/H [KW]	NET SENSIBLE BTU/H [KW]	NET LATENT BTU/H [KW]	SEER2	EER2	INDOOR CFM [L/S]
RA16AZ24AJ3C	RH3VZ2417STACN	22,800 [6.7]	17,600 [5.2]	5,200 [1.5]	16.0	10.5	750 [354.0]
RA16AZ36AJ3C	RH3VZ3617STACN	34,200 [10.0]	26,600 [7.8]	7,600 [2.2]	16.0	10.5	1,125 [530.9]
RA16AZ48AJ3C	RH3VZ4821STACN	45,500 [13.3]	35,500 [10.4]	10,000 [2.9]	16.0	10.5	1,425 [672.5]
RA16AZ60AJ3C	RH3VZ6024STACN	55,500 [16.3]	43,000 [12.6]	12,500 [3.7]	15.5	9.8	1,675 [790.5]

NOTE: This data includes DTC (Designated Test Combination) ratings and is for reference purposes only. A full listing of official ratings and system match-ups, along with downloadable certificates, can be accessed from the AHRI website: www.ahridirectory.org.

[] Designates Metric Conversions

Integrated Controls



EcoNet® is smart, technology developed exclusively by Rheem that allows Heating, Cooling, and Water Heating products to communicate with each other on one integrated network.

THE ECONE® SMART THERMOSTAT

BUILT-IN WIFI

4.3" LCD TOUCH SCREEN

LOCAL WEATHER – Current conditions plus 6-day forecast

5 OPERATING MODES – Heat, Cool, Auto, Emergency Heat and Fan Only

7-DAY PROGRAMMABLE SCHEDULE – Offers comfort without thought

ONE-TOUCH AWAY – Quickly switch to your energy-saving away preferences

VACATION SCHEDULING – Allows you to save while you're away and come home to comfort

STANDBY SCREEN – Displays indoor temperature and current weather



RETST800SYS

OPERATIONAL FEATURES

AUTOMATIC CHANGEOVER – Transitions between heating and cooling automatically to keep the house comfortable

INTEGRATED WATER CONTROL – Enables easy water heater management

SMOOTH ARRIVAL – Prompts the system to start ahead of schedule to ensure the home is at the desired temperature at the scheduled time

HUMIDITY CONTROL – Supports humidifier accessories or over-cool based dehumidification

DETAILED OPERATING STATUS – View pertinent equipment status information and run times

CONTINUOUS FAN – Offers 5 speeds (Low, Medium Low, Medium, Medium High, High)

SHORT-CYCLE PROTECTION – Avoids damage to equipment from short run cycles

MONITORING & REMOTE CONTROL FEATURES

ACTIVE MONITORING – Alerts to problems that need immediate attention

REMOTE CONTROL – Allows adjusting of comfort and settings from anywhere using a mobile device

SERVICE ALERTS – Sends routine maintenance reminders

AIR FILTER MONITORING – Detects when it's time to replace the air filter

ALARM HISTORY – Displays time-stamped alarm codes with clear descriptions



The new degree of comfort®

GENERAL TERMS OF LIMITED WARRANTY*

Rheem will furnish a replacement for any part of this product which fails in normal use and service within the applicable period stated, in accordance with the terms of the limited warranty.

Conditional Unit Replacement
(Registration Required)..... Ten (10) Years
Parts Ten (10) Years

***For complete details of the Limited and Conditional Warranties, including applicable terms and conditions, contact your local contractor or the Manufacturer for a copy of the product warranty certificate.**

Before proceeding with installation, refer to installation instructions packaged with each model, as well as complying with all Federal, State, Provincial, and Local codes, regulations, and practices.

© 2023 Rheem Manufacturing Company. Rheem trademarks owned by Rheem Manufacturing Company.

In keeping with its policy of continuous progress and product improvement, Rheem reserves the right to make changes without notice.

Rheem Heating, Cooling & Water Heating • 5600 Old Greenwood Road
Fort Smith, Arkansas 72908 • www.rheem.com

Rheem Canada Ltd./Ltée • 125 Edgeware Road, Unit 1
Brampton, Ontario • L6Y 0P5 • rheem.ca