



MEDIUM PROFILE UNIT COOLER

Medium to Large Walk-Ins
Cooler and Freezer Applications



Air Defrost
18,200 to 76,900 BTUH

Electric Defrost
11,000 to 64,300 BTUH

Hot Gas Defrost
11,000 to 64,300 BTUH



MEDIUM PROFILE UNIT COOLER

Features

Russell's Medium Profile Unit Coolers are the perfect evaporator solution for medium to large walk-in coolers and freezers. Designed with efficiency, performance and service in mind, the Medium Profile line truly stands out from the competition. The unit coolers were engineered to meet the Department of Energy's new AWEF* performance regulations and all feature energy-efficient rail-mount Dual Speed EC Motors. For maximum performance, all units are circuited for multiple refrigerants and feature optimized circuit patterns, enhanced surface coil tubing, and new high efficiency fan and venturi designs. The Medium Profile product line has several serviceability features including rail-mount motors, easily removable fan guards and modular fan panels, face mount defrost heaters, hinged drain pans, and shipping pallets designed to facilitate quicker installation.

SIZES

There are a wide array of sizes available with capacities ranging from 11,000 to 76,900 BTUH at a 10° TD. Models are available with air flow spanning a range of 2,090 to 9,580 CFM.

HOUSING

Each unit is constructed with a rust-free, heavy gauge, textured, aluminum housing which is light weight yet extremely durable. Models feature hinged one-piece drain pans to allow for convenient servicing and maintenance. Hanger holes are provided on all units for fast installation.

COIL

Seamless copper tubes are staggered and mechanically expanded into corrugated aluminum fins to assure maximum heat transfer. Die formed fin collars are provided for accurate fin spacing. Top panel is fastened directly to the tube sheets of the coil to provide high structural strength. Electric Defrost and Hot Gas Defrost Models are available in both 6 FPI and 4 FPI.

MOTORS

All models feature highly efficient Dual Speed Electronically Commutated (EC) motors which are compliant with California Title 24 regulations¹.

FANS & FAN GUARDS

Powerful heavy-duty aluminum fans are individually balanced to provide vibration free operation. Standard heavy-gauge wire fan guards are UL/cUL-approved epoxy coated for corrosion resistance. Air throw for Medium Profile Unit Coolers is 75 ft.

REFRIGERANTS

Medium Profile Unit Coolers are optimized for multiple refrigerants including R404A, R407A, R448A, R449A and R744 DX (CO₂). Please specify system refrigerant requirements when ordering. A separate compartment is provided for all refrigerant connections which allows ample room for internal mounting of expansion valves.

ELECTRICAL

Available in 115V/1², 208/230V/1², 208-230V/3², 460V/1 or 460/3². A large compartment is supplied for all electrical components and is easily accessible by removing the end panel. All models are UL and cUL listed.

AIR DEFROST

Air Defrost models (RM6A) are designed for use in coolers at +35°F and warmer.

ELECTRIC DEFROST

Electric Defrost models (RM6E or RM4E) are designed for use in coolers and freezers between 35°F to -30°F. Defrost heaters are mounted on the air intake side of the unit for optimal performance and easy maintenance. Heaters are installed inside the drain pan for fast, reliable drainage. Fixed defrost termination, fan delay and heater safety controls are factory mounted for optimum performance of each control function.

HOT GAS DEFROST

There are two types of Hot Gas Defrost models available: 3-pipe Hot Gas models (RM6H or RM4H) and 2-pipe Hot Gas Reverse Cycle units (RM6G or RM4G). Hot Gas Defrost models are designed for use in coolers and freezers between 35°F and -30°F. All units include fixed defrost termination and fan delay controls which are factory mounted for optimum performance of each control function. Hot Gas Defrost models feature electric drain pan heaters making it possible to open the hinged drain pan for easy cleaning and servicing. Refer to the current Russell Technical Bulletin for piping.

Optional Features

- EcoNet[®] Enabled Controller³ (factory-installed)
- EcoNet[®] Command Center (loose)
- Thermostat - Mechanical or Electric (mounted or loose)
- Thermostatic Expansion Valve (mounted or loose)
- Adjustable Defrost Termination
- Electronic Expansion Valve (mounted or loose)
- Liquid Line Solenoid Valve (mounted or loose)
- Insulated Drain Pan
- Painted Cabinet (White or Black)
- Coated Cabinet
- Stainless Steel Cabinet
- Coated Coil (Russproof, Bronz-Glow, or Electrofin[®])
- Suction/Liquid Heat Exchanger (loose)

Notes

- * AWEF (Annual Walk-in Energy Factor)
- 1. Single Compressor system without variable capacity.
- 2. Some limitations apply. For specific electrical offering, consult electrical data tables in this brochure.
- 3. EcoNet Control Package includes: EEV; suction pressure transducer; suction, entering air coil temp. thermistors; local on-board two-row backlit LCD display and push-button adjustments. (Controller replaces TXV, liquid line solenoid valve, room thermostat, defrost termination and fan delay, and time clock.)

MEDIUM PROFILE UNIT COOLER

Highlighted Features and Options



FANS AND HOUSING

- 24" heavy duty aluminum fans are balanced for vibration-free operation
- High efficiency deep draw venturi provides optimal air flow
- Removeable end panels
- NSF approved



COILS AND DEFROST HEATERS

- Available in 4 or 6 fins per inch (FPI)
- Electric defrost heaters are mounted on the air intake coil face to provide easy service access
- The drain pan heater is affixed to the drain pan and is easily accessed for service or cleaning

ECONET ENABLED UNIT COOLERS (Optional)

- Developed in conjunction with Rheem Manufacturing specifically for walk-in coolers and freezers — it builds on the reliability and efficiency of Rheem's EcoNet technology
- Saves energy in refrigeration systems through precise superheat and space temperature control, fan cycling, and controlling how often the system goes into defrost based on compressor runtime
- Eliminates unnecessary defrosts
 - Maximizes energy efficiency with less compressor runtime
 - Reduces fan speed to 50% during off cycle for energy savings
- Can be used with a condensing unit in single and multiple evaporator installations as a group
- Optional **EcoNet Command Center** with intuitive graphical interface controls up to 32 devices (including the Command Center) through one display, provides continuous communication between system components, and the remote mount display allows for EcoNet Enabled Unit Coolers to be programmed, monitored and troubleshoot outside of the space being cooled

ELECTRICAL AND PIPING

- End panels slide out for easy service from the front or sides of the unit
- Ample room in electrical and piping compartments for easy access

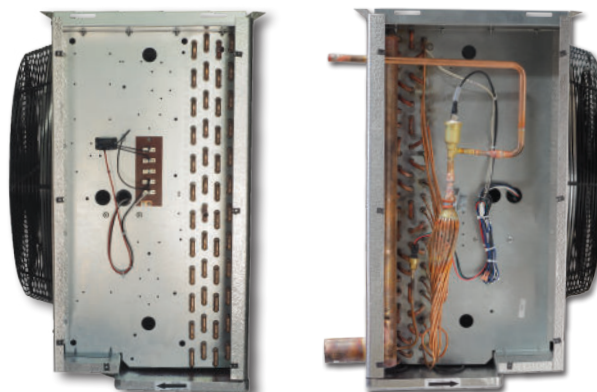

MEDIUM PROFILE UNIT COOLER

MODEL NUMBER NOMENCLATURE

CONFIGURABLE BASE MODEL

R	M	6	E	153	D	D	A
Brand	Style	Fins Per Inch (FPI)	Defrost Type	BTUH in Hundreds	Unit Voltage ¹	Motor Type	Vintage
R = Russell	M = Medium Profile	4 6	A = Air E = Electric H = Hot Gas 3-Pipe G = Hot Gas Reverse		A = 115/1/60 D = 208-230/1/60 E = 208-230/3/60 F = 460/1/60 G = 460/3/60	D = Dual Speed EC	

Note:

1. 50 Hz available. Contact Factory for additional information.

EVAPORATOR APPLICATION RATINGS

Multiple conditions combine to determine the application capacity of an evaporator. Walk-in space temperature, relative humidity, saturated suction temperature difference, and outdoor ambient temperature. All of the factors are considered when calculating an evaporator application rating. These ratings are considerably higher than the net capacity value used for DOE ratings (AWEF).

The AWEF of an evaporator is calculated using the dry coil capacity and the daily evaporator power consumption. Power consumption included fan and defrost power. Evaporator net capacity reported to the DOE database is dry coil capacity less the full power fan watts. DOE test conditions are at 10°F evaporator/SST temperature difference and less than 50% relative humidity and 96°F liquid temperature. These conditions create a uniform test method, but should not be used for equipment selection. The equipment selected would be too large for the application.

Russell's published application ratings are a guideline for proper equipment selection. They account for true operating conditions experienced by equipment.

MEDIUM PROFILE UNIT COOLER

Application Rating and Electrical Data - Air Defrost Models - 6 FPI

Model Number	BTUH Capacity @ 25°F S.T & 10°F TD		CFM	No. of Fans	Total Fan Motor AMPS			MCA	MOPD
	R404A/ R744 DX (CO ₂)	R407A/ R448A/ R449A [^]			Dual Speed EC [†] Motors				
					Motor Voltage				
					115V/1	208- 230V/1	460V/1		
RM6A182*DA RM6A220*DA	18,200 22,000	21,100 25,800	3,190 2,950	1	3.2	1.9	1.2	15.0	20
RM6A276*DA RM6A370*DA RM6A442*DA	27,600 37,000 44,200	32,300 43,100 51,900	6,950 6,380 5,900	2	6.4	3.8	2.4	15.0	20
RM6A549*DA RM6A658*DA	54,900 65,800	64,200 76,900	9,580 8,860	3	9.6	5.7	3.6	15.0	20

* Asterisk represents a variable character based on voltage ordered. See page 4 for nomenclature.

[^] R407A, R448A and R449A are rated at dew point temperature. Use R407A capacity ratings for R407C and R407F.

[†] Dual Speed EC motors are compliant with California Title 24 regulations.

Models were designed in anticipation of the July 2020 Department of Energy Annual Walk-in Energy Factor (AWEF) regulations for evaporators for Walk-in Coolers and Freezers in boxes less than 3,000 sq. ft. See page 16 for AWEF compliance ratings.

Fan guards easily removeable for quick access to fan blades and rail-mounted motors

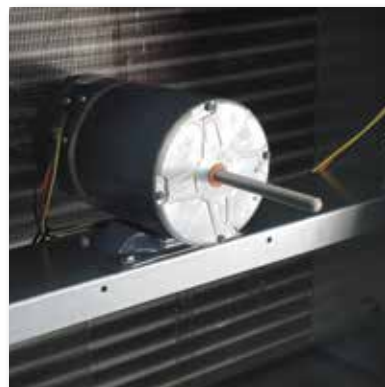

MEDIUM PROFILE UNIT COOLER

Application Rating and Electrical Data - Electric Defrost Models

Model Number	BTUH Capacity @ -20°F S.T. & 10°F TD ¹		CFM	No. of Fans	Total Fan Motor AMPS	
	R404A/ R744 DX(CO ₂)	R407A/ R448A/ R449A [^]			Dual Speed EC Motors [†]	
					Motor Voltage	
					208-230V/1	460V/1

6 FPI

RM6E153*DA	15,300	17,400	2,250	1	1.9	1.2
RM6E184*DA	18,400	21,100	2,090			
RM6E311*DA	31,100	35,700	4,500	2	3.8	2.4
RM6E374*DA	37,400	42,900	4,180			
RM6E469*DA	46,900	53,600	6,750	3	5.7	3.6
RM6E564*DA	56,400	64,300	6,270			

4 FPI

RM4E110*DA	11,000	12,400	2,350	1	1.9	1.2
RM4E143*DA	14,300	16,200	2,210			
RM4E232*DA	23,200	26,100	4,690	2	3.8	2.4
RM4E288*DA	28,800	32,700	4,420			
RM4E336*DA	33,600	38,300	7,040	3	5.7	3.6
RM4E419*DA	41,900	47,600	6,640			

Model Number	208-230V/1				Heater Amps	Heater Watts
	MCA		MOPD			
	Base Model	EcoNet Enabled ²	Base Model	EcoNet Enabled ²	208-230V/1	

6 FPI

RM6E153DDA	15.0	20.5	20	25	19.5	4,480
RM6E184DDA						
RM6E311DDA	15.0	40.5	20	45	38.5	8,860
RM6E374DDA						

4 FPI

RM4E110DDA	15.0	20.5	20	25	19.5	4,480
RM4E143DDA						
RM4E232DDA	15.0	40.5	20	45	38.5	8,860
RM4E288DDA						

Notes:

1.

Capacity Correction for Electric Defrost Evaporators						
S.S.T. (Dew)	20°F	0°F	-10°F	-20°F	-30°F	-40°F
Multiply Capacity by:	1.15	1.075	1.0375	1	0.9625	0.925

2. EcoNet Enabled Units are not powered by Condensing Unit so Defrost Heaters are incorporated into shown MCA/MOPD.

* Each asterisk represents a variable character based on voltage ordered. See page 4 for nomenclature.

[^] R407A, R448A and R449A are rated at dew point temperature. Use R407A capacity ratings for R407C and R407F.

[†] Dual Speed EC motors are compliant with California Title 24 regulations.

Models were designed in anticipation of the July 2020 Department of Energy Annual Walk-in Energy Factor (AWEF) regulations for evaporators for Walk-in Coolers and Freezers in boxes less than 3,000 sq. ft. See page 16 for AWEF compliance ratings.

MEDIUM PROFILE UNIT COOLER

Application Rating and Electrical Data - Electric Defrost Models continued

Model Number	208-230V/3				Heater Amps	Heater Watts
	MCA		MOPD		208-230V/3	
	Base Model	EcoNet Enabled ¹	Base Model	EcoNet Enabled ¹		

6 FPI

RM6E153EDA RM6E184EDA	15.0	15.0	20	25	11.2	4,480
RM6E311EDA RM6E374EDA	15.0	23.2	20	25	22.2	8,860
RM6E469EDA RM6E564EDA	15.0	35.5	20	40	33.5	13,340

4 FPI

RM4E110EDA RM4E143EDA	15.0	15.0	20	25	11.2	4,480
RM4E232EDA RM4E288EDA	15.0	23.2	20	25	22.2	8,860
RM4E336EDA RM4E419EDA	15.0	35.5	20	40	33.5	13,340

Model Number	460V/1				Heater Amps	Heater Watts
	MCA		MOPD		460V/1	
	Base Model	EcoNet Enabled ¹	Base Model	EcoNet Enabled ¹		

6 FPI

RM6E153FDA RM6E184FDA	15.0	15.0	20	25	9.7	4,480
RM6E311FDA RM6E374FDA	15.0	20.3	20	25	19.3	8,860
RM6E469FDA RM6E564FDA	15.0	30.0	20	35	29.0	13,340

4 FPI

RM4E110FDA RM4E143FDA	15.0	15.0	20	25	9.7	4,480
RM4E232FDA RM4E288FDA	15.0	20.3	20	25	19.3	8,860
RM4E336FDA RM4E419FDA	15.0	30.0	20	35	29.0	13,340

Notes:

1. EcoNet Enabled Units are not powered by Condensing Unit so Defrost Heaters are incorporated into shown MCA/MOPD.

^ R407A, R448A and R449A are rated at dew point temperature. Use R407A capacity ratings for R407C and R407F.

† Dual Speed EC motors are compliant with California Title 24 regulations.

Models were designed in anticipation of the July 2020 Department of Energy Annual Walk-in Energy Factor (AWEF) regulations for evaporators for Walk-in Coolers and Freezers in boxes less than 3,000 sq. ft. See page 16 for AWEF compliance ratings.

MEDIUM PROFILE UNIT COOLER

Application Rating and Electrical Data - Electric Defrost Models continued

Model Number	460V/3				Heater Amps	Heater Watts
	MCA		MOPD			
	Base Model	EcoNet Enabled ¹	Base Model	EcoNet Enabled ¹	460V/3	

6 FPI

RM6E153GDA RM6E184GDA	15.0	15.0	20	20	5.6	4,480
RM6E311GDA RM6E374GDA	15.0	15.0	20	20	11.1	8,860
RM6E469GDA RM6E564GDA	15.0	17.7	20	20	16.7	13,340

4 FPI

RM4E110GDA RM4E143GDA	15.0	15.0	20	20	5.6	4,480
RM4E232GDA RM4E288GDA	15.0	15.0	20	20	11.1	8,860
RM4E336GDA RM4E419GDA	15.0	17.7	20	20	16.7	13,340

Notes:

1. EcoNet Enabled Units are not powered by Condensing Unit so Defrost Heaters are incorporated into shown MCA/MOPD.

^ R407A, R448A and R449A are rated at dew point temperature. Use R407A capacity ratings for R407C and R407F.

† Dual Speed EC motors are compliant with California Title 24 regulations.

Models were designed in anticipation of the July 2020 Department of Energy Annual Walk-in Energy Factor (AWEF) regulations for evaporators for Walk-in Coolers and Freezers in boxes less than 3,000 sq. ft. See page 16 for AWEF compliance ratings.



**Supports are bolted to pallet and unit cooler
for product safety and quicker installation**

MEDIUM PROFILE UNIT COOLER

Application Rating and Electrical Data - Hot Gas 3-Pipe Defrost Models

Hot Gas 3-Pipe Model Number ⁺	BTUH Capacity @ -20°F S.T. & 10°F TD ¹		CFM	No. of Fans	Total Fan Motor AMPS		MCA	MOPD
	R404A/ R744 DX(CO ₂)	R407A/ R448A/ R449A [^]			Dual Speed EC Motors [†]			
					Motor Voltage			
					208-230V/1	460V/1		

6 FPI

RM6H153*DA	15,300	17,400	2,250	1	1.9	1.2	15.0	20
RM6H184*DA	18,400	21,100	2,090					
RM6H311*DA	31,100	35,700	4,500	2	3.8	2.4	15.0	20
RM6H374*DA	37,400	42,900	4,180					
RM6H469*DA	46,900	53,600	6,750	3	5.7	3.6	15.0	20
RM6H564*DA	56,400	64,300	6,270					

4 FPI

RM4H110*DA	11,000	12,400	2,350	1	1.9	1.2	15.0	20
RM4H143*DA	14,300	16,200	2,210					
RM4H232*DA	23,200	26,100	4,690	2	3.8	2.4	15.0	20
RM4H288*DA	28,800	32,700	4,420					
RM4H336*DA	33,600	38,300	7,040	3	5.7	3.6	15.0	20
RM4H419*DA	41,900	47,600	6,640					

Hot Gas 3-Pipe Model Number ⁺	Drain Pan Heater Amps		Drain Pan Heater Watts
	208-230V/1	460V/1	

6 FPI

RM6H153*DA	6.4	3.2	1,480
RM6H184*DA			
RM6H311*DA	12.9	6.4	2,960
RM6H374*DA			
RM6H469*DA	19.3	9.7	4,440
RM6H564*DA			

4 FPI

RM4H110*DA	6.4	3.2	1,480
RM4H143*DA			
RM4H232*DA	12.9	6.4	2,960
RM4H288*DA			
RM4H336*DA	19.3	9.7	4,440
RM4H419*DA			

Notes:

Capacity Correction for Hot Gas Defrost Evaporators						
S.S.T. (Dew)	20°F	0°F	-10°F	-20°F	-30°F	-40°F
Multiply Capacity by:	1.15	1.075	1.0375	1	0.9625	0.925

* Each asterisk represents a variable character based on voltage ordered. See page 4 for nomenclature.

+ Hot Gas models include an electric drain pan. † Dual Speed EC motors are compliant with California Title 24 regulations.

^ R407A, R448A and R449A are rated at dew point temperature. Use R407A capacity ratings for R407C and R407E.

Models were designed in anticipation of the July 2020 Department of Energy Annual Walk-in Energy Factor (AWEF) regulations for evaporators for Walk-in Coolers and Freezers in boxes less than 3,000 sq. ft. See page 16 for AWEF compliance ratings.

Hot Gas 3-Pipe Model

The system uses 3 pipes — 1 for liquid line, 1 for suction line and 1 for hot gas. The hot gas is taken from the discharge line, between the compressor and the condenser, through a hot-gas solenoid valve to the distributor tee then through the coil.

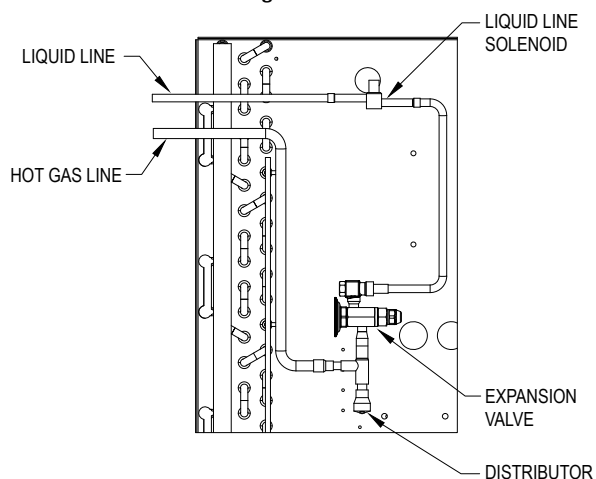

MEDIUM PROFILE UNIT COOLER

Application Rating and Electrical Data - Hot Gas Reverse Cycle Defrost Models

Hot Gas Reverse Cycle Model Number ⁺	BTUH Capacity @ -20°F S.T. & 10°F TD ¹		CFM	No. of Fans	Total Fan Motor AMPS		MCA	MOPD
	R404A/ R744 DX(CO ₂)	R407A/ R448A/ R449A [^]			Dual Speed EC Motors [†]			
					Motor Voltage			
					208-230V/1	460V/1		

6 FPI

RM6G153*DA	15,300	17,400	2,250	1	1.9	1.2	15.0	20
RM6G184*DA	18,400	21,100	2,090					
RM6G311*DA	31,100	35,700	4,500	2	3.8	2.4	15.0	20
RM6G374*DA	37,400	42,900	4,180					
RM6G469*DA	46,900	53,600	6,750	3	5.7	3.6	15.0	20
RM6G564*DA	56,400	64,300	6,270					

4 FPI

RM4G110*DA	11,000	12,400	2,350	1	1.9	1.2	15.0	20
RM4G143*DA	14,300	16,200	2,210					
RM4G232*DA	23,200	26,100	4,690	2	3.8	2.4	15.0	20
RM4G288*DA	28,800	32,700	4,420					
RM4G336*DA	33,600	38,300	7,040	3	5.7	3.6	15.0	20
RM4G419*DA	41,900	47,600	6,640					

Hot Gas Reverse Cycle Model Number ⁺	Drain Pan Heater Amps		Drain Pan Heater Watts
	208-230V/1	460V/1	

6 FPI

RM6G153*DA	6.4	3.2	1,480
RM6G184*DA			
RM6G311*DA	12.9	6.4	2,960
RM6G374*DA			
RM6G469*DA	19.3	9.7	4,440
RM6G564*DA			

4 FPI

RM4G110*DA	6.4	3.2	1,480
RM4G143*DA			
RM4G232*DA	12.9	6.4	2,960
RM4G288*DA			
RM4G336*DA	19.3	9.7	4,440
RM4G419*DA			

Hot Gas Reverse Cycle 2-Pipe Model

A changeover valve is located in the discharge suction line of the compressor, so that when defrost is required, the valve changes over from the normal refrigeration flow so that the discharged gas flows into the suction connection and bypasses TX valve.

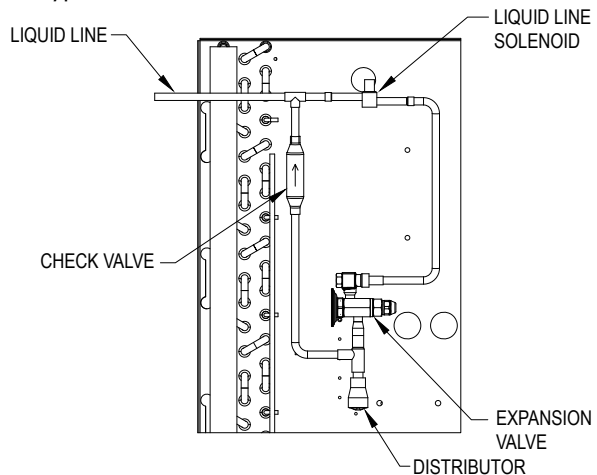

Notes:

1.

Capacity Correction for Hot Gas Defrost Evaporators						
S.S.T. (Dew)	20°F	0°F	-10°F	-20°F	-30°F	-40°F
Multiply Capacity by:	1.15	1.075	1.0375	1	0.9625	0.925

* Each asterisk represents a variable character based on voltage ordered. See page 4 for nomenclature.

+ Hot Gas models include an electric drain pan. † Dual Speed EC motors are compliant with California Title 24 regulations.

^ R407A, R448A and R449A are rated at dew point temperature. Use R407A capacity ratings for R407C and R407F.

Models were designed in anticipation of the July 2020 Department of Energy Annual Walk-in Energy Factor (AWEF) regulations for evaporators for Walk-in Coolers and Freezers in boxes less than 3,000 sq. ft. See page 16 for AWEF compliance ratings.

MEDIUM PROFILE UNIT COOLER

Distributor Nozzle and Expansion Valves - Air Defrost Models

Model Number	Part Numbers						No. of Circuits
	Nozzle @ Liq. Temp.		TXV^ @ Liq. Temp.		EEV @ Liq. Temp.		
	50°F	105°F	50°F	105°F	50°F	105°F	

R404A

6 FPI	RM6A182*DA	L-3/4	L-2	SBFSE-B-C	SBFSE-B-C	SER-B	SER-B	4
	RM6A220*DA	L-3/4	L-2-1/2	SBFSE-B-C	SBFSE-B-C	SER-B	SER-B	6
	RM6A276*DA	L-1	L-3	SBFSE-B-C	SBFSE-C-C	SER-B	SER-C	8
	RM6A370*DA	L-1-1/2	L-4	SBFSE-C-C	SBFSE-C-C	SER-C	SER-C	9
	RM6A442*DA	G-1-1/2	G-5	EBSSE-6-C	EBSSE-6-C	SER-C	SER-C	12
	RM6A549*DA	G-2	G-6	EBSSE-6-C	EBSSE-6-C	SER-C	SER-C	12
RM6A658*DA	G-2-1/2	G-8	EBSSE-6-C	EBSSE-6-C	SER-C	SER-D	16	

R407A/ R407C†

6 FPI	RM6A182*DA	L-3/4	L-2	SBFDE-B-C	SBFDE-B-C	SER-B	SER-B	4
	RM6A220*DA	L-3/4	L-2-1/2	SBFDE-B-C	SBFDE-B-C	SER-B	SER-B	6
	RM6A276*DA	L-1	L-3	SBFDE-B-C	SBFDE-B-C	SER-B	SER-C	8
	RM6A370*DA	L-1-1/2	L-4	SBFDE-C-C	SBFDE-C-C	SER-C	SER-C	9
	RM6A442*DA	G-1-1/2	G-5	SBFDE-C-C	SBFDE-C-C	SER-C	SER-C	12
	RM6A549*DA	G-2	G-6	EBSDE-7-C	SBFDE-C-C	SER-C	SER-C	12
RM6A658*DA	G-2-1/2	G-8	EBSDE-7-C	EBSDE-7-C	SER-C	SER-D	16	

R448A/ R449A†

6 FPI	RM6A182*DA	L-3/4	L-2	SBFDE-B-C	SBFDE-B-C	SER-B	SER-B	4
	RM6A220*DA	L-3/4	L-2-1/2	SBFDE-B-C	SBFDE-B-C	SER-B	SER-B	6
	RM6A276*DA	L-1	L-3	SBFDE-C-C	SBFDE-C-C	SER-B	SER-C	8
	RM6A370*DA	L-1-1/2	L-4	SBFDE-C-C	SBFDE-C-C	SER-C	SER-C	9
	RM6A442*DA	G-1-1/2	G-5	SBFDE-C-C	EBSDE-7-C	SER-C	SER-C	12
	RM6A549*DA	G-2	G-6	EBSDE-7-C	EBSDE-7-C	SER-C	SER-C	12
RM6A658*DA	G-2-1/2	G-8	EBSDE-7-C	EBSDE-7-C	SER-C	SER-D	16	

Note: The distributor lines are 3/16" tube & 21" long.

* Each asterisk represents a variable character based on voltage ordered. See page 4 for nomenclature.

^ TXV selections are based on +25°F suction temp., 8°F to 12°F evaporator TD. Contact factory for operating conditions outside of this range.

† SBFDE expansion valves are compatible with R407A, R448A and R449A/B. For other valves, follow manufacturers selection guidelines.

Base models (no factory-mounted components) include nozzles sized for 100°F liquid shipped loose.

TYPICAL APPLICATIONS:



Small to Medium Warehouses



Industrial and Pharmaceuticals



Walk-in Coolers and Freezers

MEDIUM PROFILE UNIT COOLER

Distributor Nozzle and Expansion Valves - Electric Defrost Models

Model Number	Part Numbers						No. of Circuits
	Nozzle @ Liq. Temp.		TXV [^] @ Liq. Temp.		EEV @ Liq. Temp.		
	50°F	105°F	50°F	105°F	50°F	105°F	

R404A

6 FPI	RM6E153*DA	L-1-1/2	L-2-1/2	SBFSE-B-Z	SBFSE-B-Z	SER-B	SER-B	6
	RM6E184*DA	L-1-1/2	L-3	SBFSE-B-Z	SBFSE-C-Z	SER-B	SER-B	8
	RM6E311*DA	G-2-1/2	G-5	SBFSE-C-Z	EBSSSE-6-Z	SER-B	SER-C	12
	RM6E374*DA	G-3	G-6	EBSSSE-6-Z	EBSSSE-6-Z	SER-C	SER-C	16
	RM6E469*DA	G-4	G-10	EBSSSE-6-Z	EBSSSE-7-1/2-Z	SER-C	SER-C	18
	RM6E564*DA	G-5	G-12	EBSSSE-7-1/2-Z	EBSSSE-10-Z	SER-C	SER-C	24
4 FPI	RM4E110*DA	L-1	L-2	SBFSE-A-Z	SBFSE-A-Z	SER-A	SER-A	4
	RM4E143*DA	L-1-1/2	L-2-1/2	SBFSE-A-Z	SBFSE-B-Z	SER-A	SER-B	6
	RM4E232*DA	L-2	L-4	SBFSE-B-Z	SBFSE-C-Z	SER-B	SER-B	9
	RM4E288*DA	G-2-1/2	G-5	SBFSE-C-Z	EBSSSE-6-Z	SER-B	SER-C	12
	RM4E336*DA	G-3	G-6	SBFSE-C-Z	EBSSSE-6-Z	SER-C	SER-C	12
	RM4E419*DA	G-4	G-8	EBSSSE-6-Z	EBSSSE-6-Z	SER-C	SER-C	16

R407A/ R407C†

6 FPI	RM6E153*DA	L-1-1/2	L-2-1/2	SBFDE-B-Z	SBFDE-B-Z	SER-A	SER-B	6
	RM6E184*DA	L-1-1/2	L-3	SBFDE-B-Z	SBFDE-B-Z	SER-B	SER-B	8
	RM6E311*DA	G-2-1/2	G-5	SBFDE-C-Z	SBFDE-C-Z	SER-B	SER-C	12
	RM6E374*DA	G-3	G-6	SBFDE-C-Z	EBSD-7-Z	SER-C	SER-C	16
	RM6E469*DA	G-4	G-10	EBSD-7-Z	EBSD-7-Z	SER-C	SER-C	18
	RM6E564*DA	G-5	G-12	EBSD-7-Z	EBSD-10-Z	SER-C	SER-C	24
4 FPI	RM4E110*DA	L-1	L-2	SBFDE-A-Z	SBFDE-A-Z	SER-A	SER-A	4
	RM4E143*DA	L-1-1/2	L-2-1/2	SBFDE-B-Z	SBFDE-B-Z	SER-A	SER-B	6
	RM4E232*DA	L-2	L-4	SBFDE-C-Z	SBFDE-C-Z	SER-B	SER-B	9
	RM4E288*DA	G-2-1/2	G-5	SBFDE-C-Z	SBFDE-C-Z	SER-B	SER-C	12
	RM4E336*DA	G-3	G-6	SBFDE-C-Z	SBFDE-C-Z	SER-B	SER-C	12
	RM4E419*DA	G-4	G-8	EBSD-7-Z	EBSD-7-Z	SER-C	SER-C	16

R448A/ R449A†

6 FPI	RM6E153*DA	L-1-1/2	L-2-1/2	SBFDE-B-Z	SBFDE-B-Z	SER-A	SER-B	6
	RM6E184*DA	L-1-1/2	L-3	SBFDE-B-Z	SBFDE-B-Z	SER-B	SER-B	8
	RM6E311*DA	G-2-1/2	G-5	SBFDE-C-Z	SBFDE-C-Z	SER-B	SER-C	12
	RM6E374*DA	G-3	G-6	EBSD-7-Z	EBSD-7-Z	SER-C	SER-C	16
	RM6E469*DA	G-4	G-10	EBSD-7-Z	EBSD-7-Z	SER-C	SER-C	18
	RM6E564*DA	G-5	G-12	EBSD-10-Z	EBSD-10-Z	SER-C	SER-C	24
4 FPI	RM4E110*DA	L-1	L-2	SBFDE-A-Z	SBFDE-A-Z	SER-A	SER-A	4
	RM4E143*DA	L-1-1/2	L-2-1/2	SBFDE-A-Z	SBFDE-A-Z	SER-A	SER-B	6
	RM4E232*DA	L-2	L-4	SBFDE-B-Z	SBFDE-C-Z	SER-B	SER-B	9
	RM4E288*DA	G-2-1/2	G-5	SBFDE-C-Z	SBFDE-C-Z	SER-B	SER-C	12
	RM4E336*DA	G-3	G-6	SBFDE-C-Z	EBSD-7-Z	SER-B	SER-C	12
	RM4E419*DA	G-4	G-8	EBSD-7-Z	EBSD-7-Z	SER-C	SER-C	16

Note: The distributor lines are 3/16" tube & 21" long.

* Each asterisk represents a variable character based on voltage ordered. See page 4 for nomenclature.

[^] TXV selections for Electric Defrost Models are based on -20°F suction temp., 8°F to 12°F evaporator TD. Contact factory for operating conditions outside of this range. Do not use pressure limiting TXVs when the condensing unit includes a CPR valve.

† SBFDE expansion valves are compatible with R407A, R448A and R449A/B. For other refrigerant valves, follow manufacturers selection guidelines.

Base models (no factory-mounted components) include nozzles sized for 100°F liquid shipped loose.

MEDIUM PROFILE UNIT COOLER

Distributor Nozzle and Expansion Valves - Hot Gas Defrost Models

Model Number RM*H/RM*G	Part Numbers						No. of Circuits
	Nozzle @ Liq. Temp.		TXV [^] @ Liq. Temp.		EEV @ Liq. Temp.		
	50°F	105°F	50°F	105°F	50°F	105°F	

R404A

6 FPI	RM6*153*DA	L-1-1/2	L-2-1/2	SBFSE-B-Z	SBFSE-B-Z	SER-B	SER-B	6
	RM6*184*DA	G-1-1/2	G-3	SBFSE-B-Z	SBFSE-C-Z	SER-B	SER-B	8
	RM6*311*DA	G-2-1/2	G-5	SBFSE-C-Z	EBSSE-6-Z	SER-B	SER-C	12
	RM6*374*DA	G-3	G-6	EBSSE-6-Z	EBSSE-6-Z	SER-C	SER-C	16
	RM6*469*DA	G-4	G-10	EBSSE-6-Z	EBSSE-7-1/2-Z	SER-C	SER-C	18
	RM6*564*DA	G-5	G-12	EBSSE-7-1/2-Z	EBSSE-10-Z	SER-C	SER-C	24
4 FPI	RM4*110*DA	L-1	L-2	SBFSE-A-Z	SBFSE-A-Z	SER-A	SER-A	4
	RM4*143*DA	L-1-1/2	L-2-1/2	SBFSE-A-Z	SBFSE-B-Z	SER-A	SER-B	6
	RM4*232*DA	G-2	G-4	SBFSE-B-Z	SBFSE-C-Z	SER-B	SER-B	9
	RM4*288*DA	G-2-1/2	G-5	SBFSE-C-Z	EBSSE-6-Z	SER-B	SER-C	12
	RM4*336*DA	G-3	G-6	SBFSE-C-Z	EBSSE-6-Z	SER-C	SER-C	12
	RM4*419*DA	G-4	G-8	EBSSE-6-Z	EBSSE-6-Z	SER-C	SER-C	16

R407A/ R407C†

6 FPI	RM6*153*DA	L-1-1/2	L-2-1/2	SBFDE-B-Z	SBFDE-B-Z	SER-A	SER-B	6
	RM6*184*DA	G-1-1/2	G-3	SBFDE-B-Z	SBFDE-B-Z	SER-B	SER-B	8
	RM6*311*DA	G-2-1/2	G-5	SBFDE-C-Z	SBFDE-C-Z	SER-B	SER-C	12
	RM6*374*DA	G-3	G-6	SBFDE-C-Z	EBSDE-7-Z	SER-C	SER-C	16
	RM6*469*DA	G-4	G-10	EBSDE-7-Z	EBSDE-7-Z	SER-C	SER-C	18
	RM6*564*DA	G-5	G-12	EBSDE-7-Z	EBSDE-10-Z	SER-C	SER-C	24
4 FPI	RM4*110*DA	L-1	L-2	SBFDE-A-Z	SBFDE-A-Z	SER-A	SER-A	4
	RM4*143*DA	L-1-1/2	L-2-1/2	SBFDE-B-Z	SBFDE-B-Z	SER-A	SER-B	6
	RM4*232*DA	G-2	G-4	SBFDE-C-Z	SBFDE-C-Z	SER-B	SER-B	9
	RM4*288*DA	G-2-1/2	G-5	SBFDE-C-Z	SBFDE-C-Z	SER-B	SER-C	12
	RM4*336*DA	G-3	G-6	SBFDE-C-Z	SBFDE-C-Z	SER-B	SER-C	12
	RM4*419*DA	G-4	G-8	EBSDE-7-Z	EBSDE-7-Z	SER-C	SER-C	16

R448A/ R449A†

6 FPI	RM6*153*DA	L-1-1/2	L-2-1/2	SBFDE-B-Z	SBFDE-B-Z	SER-A	SER-B	6
	RM6*184*DA	G-1-1/2	G-3	SBFDE-B-Z	SBFDE-B-Z	SER-B	SER-B	8
	RM6*311*DA	G-2-1/2	G-5	SBFDE-C-Z	SBFDE-C-Z	SER-B	SER-C	12
	RM6*374*DA	G-3	G-6	EBSDE-7-Z	EBSDE-7-Z	SER-C	SER-C	16
	RM6*469*DA	G-4	G-10	EBSDE-7-Z	EBSDE-7-Z	SER-C	SER-C	18
	RM6*564*DA	G-5	G-12	EBSDE-10-Z	EBSDE-10-Z	SER-C	SER-C	24
4 FPI	RM4*110*DA	L-1	L-2	SBFDE-A-Z	SBFDE-A-Z	SER-A	SER-A	4
	RM4*143*DA	L-1-1/2	L-2-1/2	SBFDE-A-Z	SBFDE-A-Z	SER-A	SER-B	6
	RM4*232*DA	G-2	G-4	SBFDE-B-Z	SBFDE-C-Z	SER-B	SER-B	9
	RM4*288*DA	G-2-1/2	G-5	SBFDE-C-Z	SBFDE-C-Z	SER-B	SER-C	12
	RM4*336*DA	G-3	G-6	SBFDE-C-Z	EBSDE-7-Z	SER-B	SER-C	12
	RM4*419*DA	G-4	G-8	EBSDE-7-Z	EBSDE-7-Z	SER-C	SER-C	16

Note: The distributor lines are 1/4" tube & 21" long.

* Each asterisk represents a variable character based on defrost and voltage ordered. See page 4 for nomenclature.

[^] TXV selections are based on -20°F suction temp., 8°F to 12°F evaporator TD. Contact factory for operating conditions outside of this range. Do not use pressure limiting TXVs when the condensing unit includes a CPR valve.

† SBFDE expansion valves are compatible with R407A, R448A and R449A/B. For other refrigerant valves, follow manufacturers selection guidelines.

Base models (no factory-mounted components) include nozzles sized for 100°F liquid shipped loose.

MEDIUM PROFILE UNIT COOLER

Specifications - Air Defrost Models

Models	Fan Diameter (Inches)	Motor Data			Refrigerant Connections		No. of Hanger Slot Locations
		Motor Qty.	HP	RPM	Liquid Line [^]	Suction	

6 FPI

RM6A182*DA	24	1	1/3	850	3/8	7/8	4
RM6A220*DA	24	1	1/3	850	3/8	7/8	4
RM6A276* DA	24	2	1/3	850	1/2	1-1/8	6
RM6A370*DA	24	2	1/3	850	1/2	1-1/8	6
RM6A442*DA	24	2	1/3	850	5/8	1-1/8	6
RM6A549*DA	24	3	1/3	850	5/8	1-3/8	8
RM6A658*DA	24	3	1/3	850	5/8	1-3/8	8

Models	Figure	Shipping Dimensions (Inches)			Approx. Unit Wt. (Lbs.)	Approx. Ship Wt. (Lbs.)
		L	W	H		

6 FPI

RM6A182*DA	1	33.5	54	46.5	120	330
RM6A220*DA	1	33.5	54	46.5	120	330
RM6A276* DA	2	33.5	87	46.5	220	505
RM6A370*DA	2	33.5	87	46.5	220	505
RM6A442*DA	2	33.5	87	46.5	220	505
RM6A549*DA	3	33.5	120	46.5	316	691
RM6A658*DA	3	33.5	120	46.5	316	691

* Each asterisk represents a variable character based on voltage ordered. See page 4 for nomenclature.

[^] For units with mounted TXV components. See Nozzle/TXV table for distributor connection size when TXV is field installed.

1. Dimensions listed are the distance between hanger slots. Hanger slots are 3/8" deep x 1" wide.
2. Drain is 1-1/4" NPT for all models.



Russell's Medium Profile Unit Cooler can be used in combination with Next-Gen MiniCon and Next-Gen II Condensing Units to provide complete refrigeration solutions for small to medium walk-ins

MEDIUM PROFILE UNIT COOLER

Specifications - Electric and Hot Gas Models

Models RM*E/G/H	Fan Diameter (Inches)	Motor Data			Refrigerant Connections			No. of Hanger Slot Locations
		Motor Qty.	HP	RPM	Liquid Line [^]	Suction	3-Pipe Hot Gas Line	

6 FPI

RM6*153*DA	24	1	1/3	850	3/8	1-1/8	1/2	4
RM6*184*DA	24	1	1/3	850	3/8	1-1/8	1/2	4
RM6*311*DA	24	2	1/3	850	1/2	1-5/8	5/8	6
RM6*374*DA	24	2	1/3	850	5/8	1-5/8	7/8	6
RM6*469*DA	24	3	1/3	850	5/8	2-1/8	7/8	8
RM6*564*DA	24	3	1/3	850	5/8	2-1/8	7/8	8

4 FPI

RM4*110*DA	24	1	1/3	850	3/8	1-1/8	1/2	4
RM4*143*DA	24	1	1/3	850	3/8	1-1/8	1/2	4
RM4*232*DA	24	2	1/3	850	1/2	1-3/8	5/8	6
RM4*288*DA	24	2	1/3	850	1/2	1-3/8	5/8	6
RM4*336*DA	24	3	1/3	850	1/2	1-5/8	5/8	8
RM4*419*DA	24	3	1/3	850	5/8	1-5/8	7/8	8

Models RM*E/G/H RM*E/G/H	Figure	Shipping Dimensions (Inches)			Approx. Unit Wt. (Lbs.)	Approx. Ship Wt. (Lbs.)
		L	W	H		

6 FPI

RM6*153*DA	1	54	33-1/2	46	120	330
RM6*184*DA	1	54	33-1/2	46	120	330
RM6*311*DA	2	87	33-1/2	46	220	505
RM6*374*DA	2	87	33-1/2	46	220	505
RM6*469*DA	3	120	33-1/2	46	320	691
RM6*564*DA	3	120	33-1/2	46	320	691

4 FPI

RM4*110*DA	1	54	33-1/2	46	120	330
RM4*143*DA	1	54	33-1/2	46	120	330
RM4*232*DA	2	87	33-1/2	46	220	505
RM4*288*DA	2	87	33-1/2	46	220	505
RM4*336*DA	3	120	33-1/2	46	320	691
RM4*419*DA	3	120	33-1/2	46	320	691

* Each asterisk represents a variable character based on defrost and voltage ordered. See page 4 for nomenclature.

[^] For units with mounted TXV components. See Nozzle/TXV table for distributor connection size when TXV is field installed.

1. Dimensions listed are the distance between hanger slots. Hanger slots are 3/8" deep x 1" wide.
2. Drain is 1-1/4" NPT for all models.

MEDIUM PROFILE UNIT COOLER

Specifications - All Models

Department of Energy Annual Walk-In Energy Factor (AWEF) Ratings

Base Model Number	Defrost Type	FPI	AWEF
-------------------	--------------	-----	------

Cooler Models¹

RM6A182*DA	Air Defrost	6	9
RM6A220*DA	Air Defrost	6	9
RM6A276*DA	Air Defrost	6	9
RM6A370*DA	Air Defrost	6	9
RM6A442*DA	Air Defrost	6	9
RM6A549*DA	Air Defrost	6	9
RM6A658*DA	Air Defrost	6	9
RM6E153*DA	Electric Defrost	6	9
RM6E184*DA	Electric Defrost	6	9
RM6E311*DA	Electric Defrost	6	9
RM6E374*DA	Electric Defrost	6	9
RM6E469*DA	Electric Defrost	6	9
RM6E564*DA	Electric Defrost	6	9
RM6*153*DA	Hot Gas Defrost	6	9
RM6*184*DA	Hot Gas Defrost	6	9
RM6*311*DA	Hot Gas Defrost	6	9
RM6*374*DA	Hot Gas Defrost	6	9
RM6*469*DA	Hot Gas Defrost	6	9
RM6*564*DA	Hot Gas Defrost	6	9

Department of Energy Annual Walk-In Energy Factor (AWEF) Ratings

Base Model Number	Defrost Type	FPI	AWEF
-------------------	--------------	-----	------

Freezer Models²

RM6E153*DA	Electric Defrost	6	4.15
RM6E184*DA	Electric Defrost	6	4.15
RM6E311*DA	Electric Defrost	6	4.15
RM6E374*DA	Electric Defrost	6	4.15
RM6E469*DA	Electric Defrost	6	4.15
RM6E564*DA	Electric Defrost	6	4.15
RM4E110*DA	Electric Defrost	4	4.15
RM4E143*DA	Electric Defrost	4	4.15
RM4E232*DA	Electric Defrost	4	4.15
RM4E288*DA	Electric Defrost	4	4.15
RM4E336*DA	Electric Defrost	4	4.15
RM4E419*DA	Electric Defrost	4	4.15
RM6*153*DA	Hot Gas Defrost	6	4.15
RM6*184*DA	Hot Gas Defrost	6	4.15
RM6*311*DA	Hot Gas Defrost	6	4.15
RM6*374*DA	Hot Gas Defrost	6	4.15
RM6*469*DA	Hot Gas Defrost	6	4.15
RM6*564*DA	Hot Gas Defrost	6	4.15
RM4*110*DA	Hot Gas Defrost	4	4.15
RM4*143*DA	Hot Gas Defrost	4	4.15
RM4*232*DA	Hot Gas Defrost	4	4.15
RM4*288*DA	Hot Gas Defrost	4	4.15
RM4*336*DA	Hot Gas Defrost	4	4.15
RM4*419*DA	Hot Gas Defrost	4	4.15

* Each asterisk represents a variable character based upon voltage ordered. See page 4 for nomenclature.

1. If the model has a numerical value in the table above, the following statement applies: "The refrigeration system is designed and certified for use in walk-in cooler applications."
2. If the model has a numerical value in the table above, the following statement applies: "The refrigeration system is designed and certified for use in walk-in freezer applications."

MEDIUM PROFILE UNIT COOLER

Physical Dimensions

Figure 1 - Single Fan

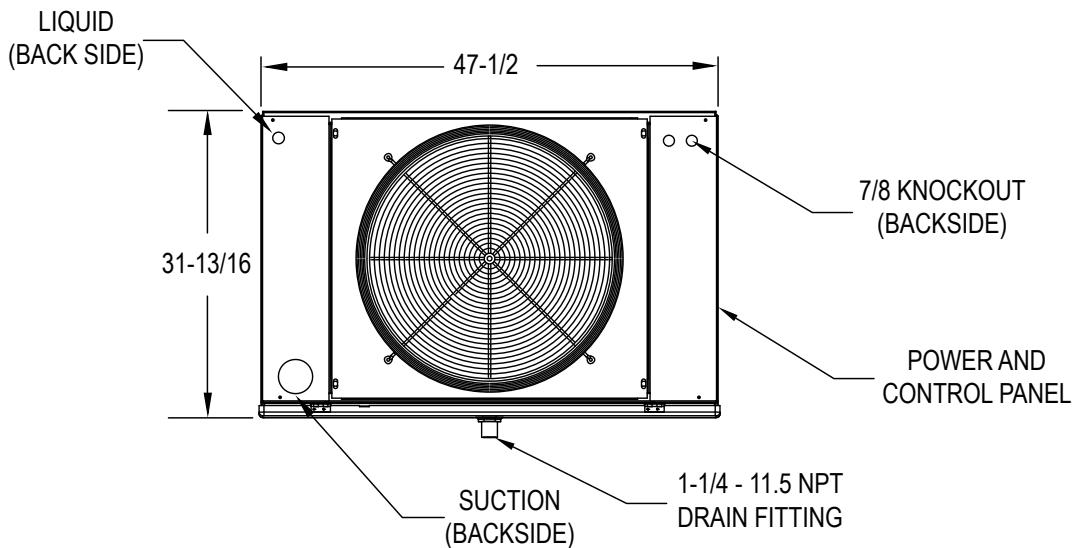
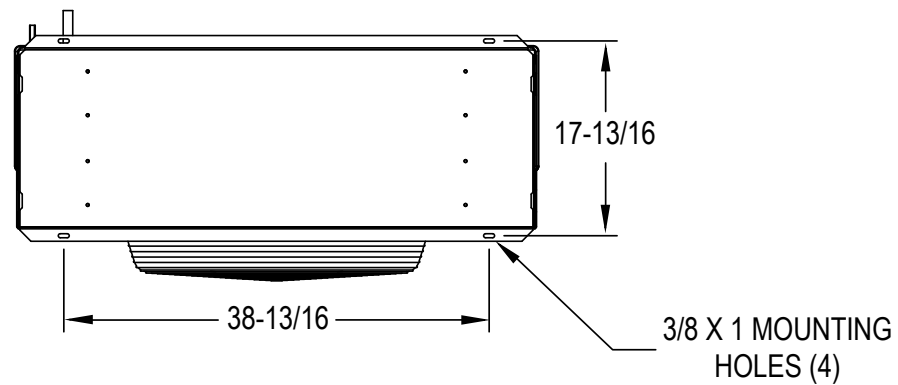
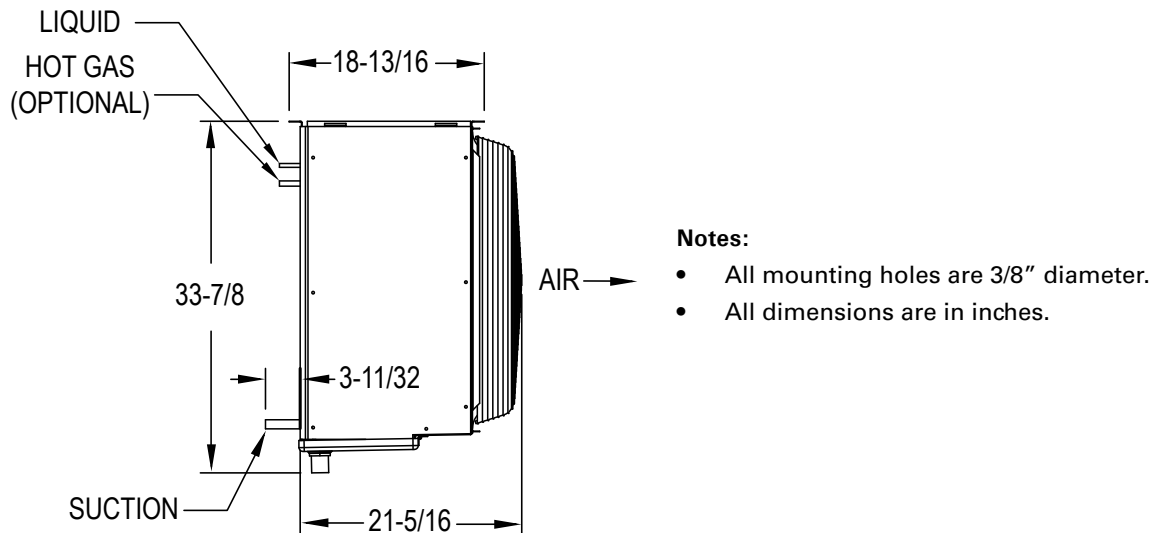

MEDIUM PROFILE UNIT COOLER

Physical Dimensions

Figure 2- Two Fan

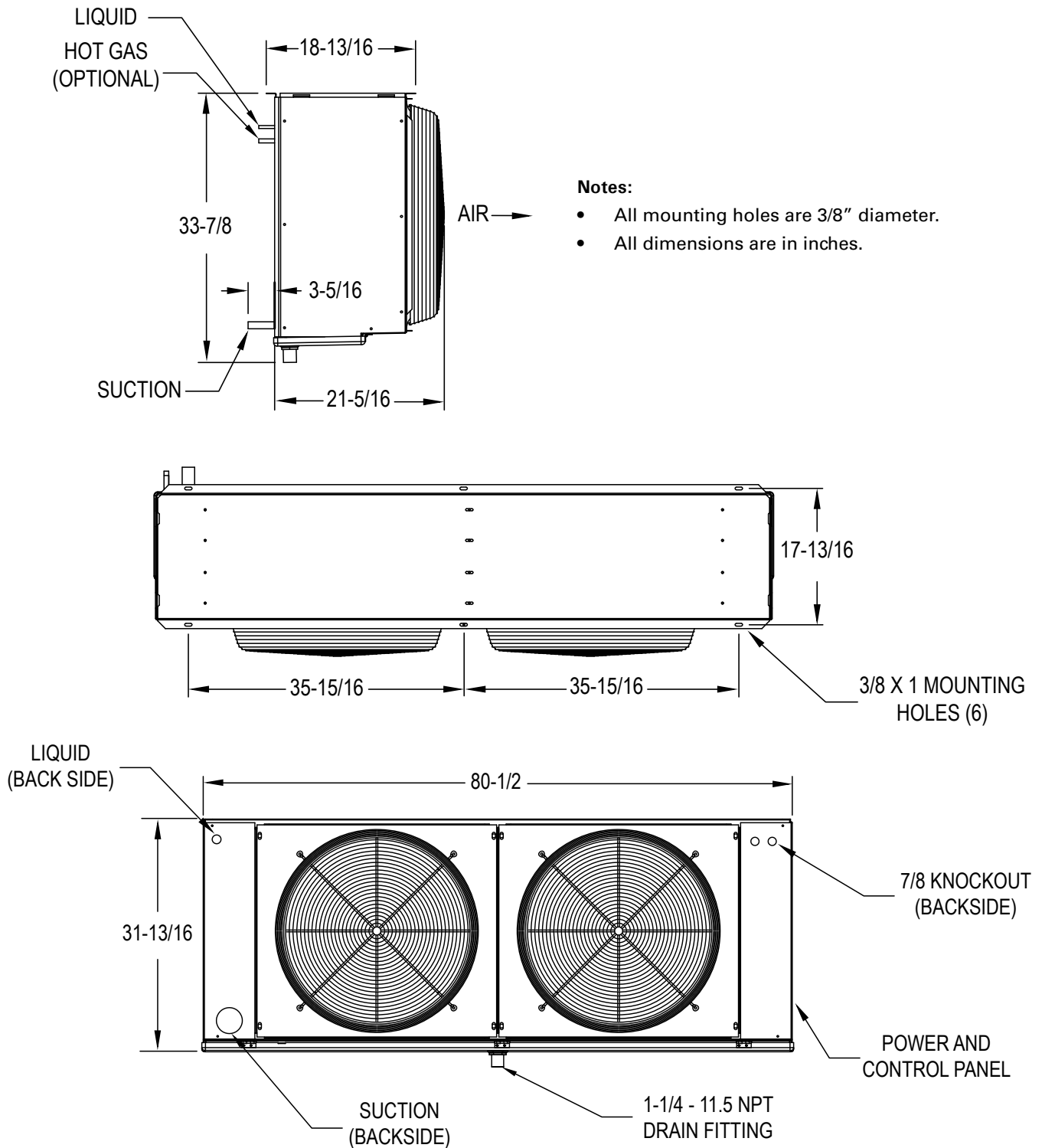

MEDIUM PROFILE UNIT COOLER

Physical Dimensions

Figure 3- Three Fan

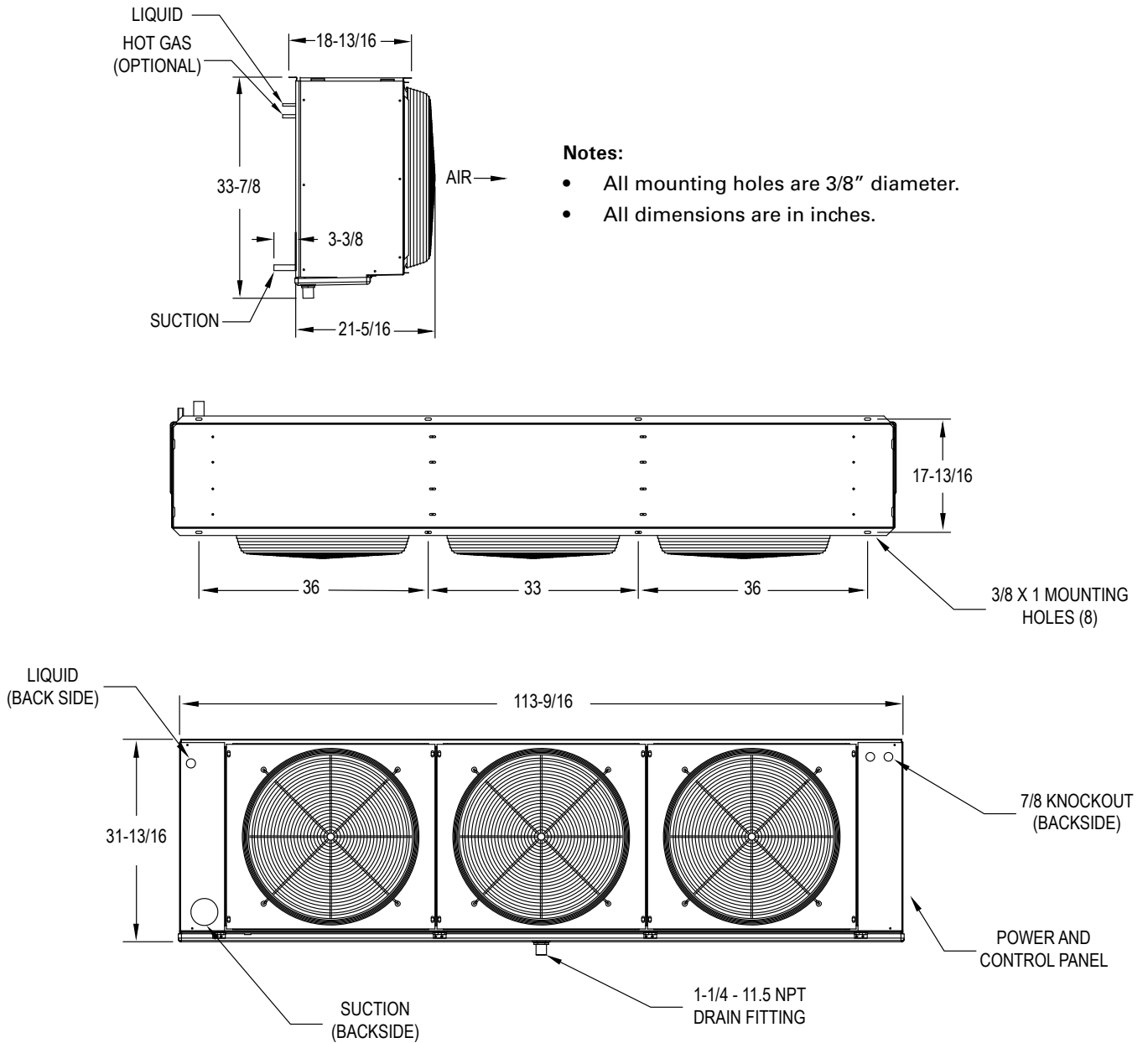

MEDIUM PROFILE UNIT COOLER

Due to continuing product development, specifications are subject to change without notice.

